



Lorin Edwin Parker

Lorinp@music.calarts.edu
<http://music.calarts.edu/~lorinp/>

Curriculum Vitae

Education and Degrees Awarded

- 2006 California Institute of the Arts – MFA, Composition: Experimental Sound Practice.
- 2003 University of Colorado at Denver - B.Sc. Music (contrabass & electric bass).
- 2003 University of Colorado at Denver - B.Sc. Audio Engineering

Other Schools and Classes Attended

- 2006 Classes & Lesson with Composer in residence Christian Wolff. California Institute of the Arts.
- 2005 Study with Paul DiMarinis. California Institute of the Arts.
- 2005 Study with Nicolas Collins. California Institute of the Arts.
- 2004 Lecture and discussion with David Wessel (CNMAT). CalArts.
- 2003 Master Class with Fred Frith. University of Colorado.
- 2003 Master Class with Janet Feder. University of Colorado / Naropa Institute.
- 2001 Double Bass Master Class with Edgar Meyer. Metropolitan State College, Denver.
- 2001 Audio Engineering Master Class with Edie Kramer. University of Colorado at Denver.
- 1998 University of California, Berkeley. Film & History Studies.
- 1997–1998 University of San Francisco. Humanities.

Notable Teachers

Composition: David Rosenboom, Mark Trayle, Sara Roberts, Gregory TS. Walker, Pauline Oliveros, Paul DeMarinis, Morton Subotnik, Christian Wolff.

Electronic Arts: Thomas Lang, Nicolas Collins

Audio Engineering: Roy Pritts

Fine Arts: John Reed, Alexandria Carrion, Beverly French

Performance Art: Gregory TS Walker, Sara Roberts, Judith Coe, Angie Belden (acting)

Contrabass: Ronald Bland, Peter Rofé

Electric Bass: Alphonso Johnson, Ronald Bland

Honors and Awards

- 2006 Selected Artist M&DE at Dartington Music and Dance Residency
- 2005 Ahmanson Grant.
- 2005 American Red Cross “Champion” award for heroism.
Presented by Colorado Governor Bill Owens for saving 2 lives
- 2005 Freeman Scholarship for Composition
- 2005 CalArts Scholarship
- 2000-2003 Colorado Scholars Award and Scholarship
- 2002 Kelley Travel Grant
- 2001 Barney / Cassell Scholarship for Musical Excellence
- 1995 Congressional Youth Service Award for community service

Commissions

- 2006 Machine Project. Los Angeles. Electronic composition and performance involving audience interaction using electromagnets and interactive metal sculpture as sound transducers for a live performance ensemble.
- 2005 Jay Stuckey. Designed and manufactured custom theremin circuits. Sound design. Metal fabrication.
- 2005 April Guthrie and Cassia Streb. Work for cello and viola involving musical sculpture as notation.
- 2005 Jacob Feinberg. 3 custom sculptures with integrated cellular phone electronics.
- 2004 Digital Explorations (Washington D.C.). Commissioned to write experimental music using consumer radio electronics.

- 2004 Micaela Cook. Commissioned to produce a custom cellular phone.
- 2003 National Science Federation. Soundtrack for educational films.
- 2002 Kelley Foundation, Commission for musical and socio-political research in Barcelona, Spain.

Major Compositions

2006:

“4000 Voices for Phonograph Over 100 Yards Away” Telegraph, Insanium, Wax Cylinders, Monologue. Bent 2006 Festival. Swing Space, New York City.

“Theme & Reprise” For 20 Mule Team and the Borax Trail. 5 String Banjo & Piano. Composed with Sarah Seelig. CalArts.

“Badwater” Oxy-acetylene Torch, Steel Bar and Amplified Water. CalArts.

“Praise to the Eternity of Intimacy” Cello, Piano and Insanium. Coreographed in collaboration with Imogine Newland and Maja Bugge. Lighting Design by Paul Bull. M&DE – Dartington College of the Arts, Totnes, Devon, U.K.

“In the Body of the Moors” Voice, Percussion, Electronics, Steel Guitar. Collaboration with Alice Kemp and Augusto Corriere. Dartington College of the Arts, Totnes, Devon, U.K.

“Score for Dance” For violin and prepared piano. Dartington College of the Arts, Totnes, Devon, U.K.

“Things Moving” Insanium, Electric Violin. With Emma Welton. M&DE – Dartington College of the Arts, Totnes, Devon, U.K.

“Ferrous Artifacts” For 3 electronic performers in a prepared space. Amplified by electromagnets and metal resonators through audience interaction. Machine Project. Los Angeles.

“The Psychoanalysis of Unreal Beings”. Monologue. Robotics and Hacked Cellular Phone. Sounding Out Series. CalArts.

2005:

“3 Courtly Lullabies”. Violin, celeste, theremin, video and robotics. CalArts.

“Phonetics of Unreal Beings”. BENT 2005 Festival, The Tank, New York City.

“Psychoanalysis for Small Electronics” Cell phone & robotics performance theater. Various Locations. Los Angeles, CA.

“Building Night”. Quintet for winds.

“Anachronistic Focal Length” Pe-eL (Lorin Parker and David Leikam). Bunny Lambert's photography exhibition opening. Los Angeles.

“Artifact II.0”. Sculptural Score for Viola and Cello. CalArts.

“Brain : Recoil”. Video Dance and Kinetic Sound Sculpture. E. Kim –
Choreographer / Videographer. Dance Showings. Lund Theater, Valencia, CA.

“Bring Your Earplugs Rock Show” Pe-eL. Los Angeles.

“Rocket Launch from the H.M.S. Queen Elizabeth II” Pe-eL. Il Corral, Los Angeles.

2004:

“Cognizant View at the Speed of Light”. Tape / Webcast.

“Hark The Morning Awaits Thee”. Snare Drum, Toothbrush and Electric Razor.

“L.A. First Response Quartet” for Four Contrabasses and Police Scanners.
Webcast.

“Blackberry Bitstream”. 2 laptops and 2 Theremins. Sounding Out, CalArts.

“Elegy for Incomplete Circuit”. Electronics, Video. Interupt / Splice Concert –
Valencia, CA.

“OktoberMarch”. Electronic Marching Band. Glendale, CA.

2003:

“Two Malevolent Electrons”. Music Improvisation Ensemble with Phillip Stearns.
Mercury Cafe, Denver, CO.

“48 Hours 48 Weeks”. Score for National Science Federation Documentary on
Antartica. NSF / Raytheon Polar Service.

2002:

“Impatient” 8 songs released as an album and performed live.

“Visual Metaphysics” Work for tape, based on Leviathan by Thomas Hobbes.

“Academia for Harpsichord”

“Trilogy Vocalise”. Presented with “Conscious Mind”. Starz Tivoli Film Center.
Denver, CO.

“Birthday Party Etude for Balloons, Kazoo and Microcassette”. Keneth King
Center, Denver, CO.

“Conscious Mind”. Short Film. Starz Tivoli Film Center, Denver, CO.

“Barcelona Fugue”. Harpsichord and Tape. Barcelona, Spain.

Inventions, Technological Designs

Steam powered synthesizer / kinetic sculpture.



Working Steam Engine Machined for Steam Synthesizer

Human detecting couch. Wireless sensor system for “Mario's Furniture”. Otis College of Design.



Metal resonators. Electromagnetic and piezo transducers for sheet metal sound projection.



“Blood Brain Barrier” Kinetic Sound Sculpture Instrument.

P.A. Klang Bot 5000. Talking, singing robot head with built in speech synthesizer.



Insanium Abstract Speech Synthesizer.



High impedance j-fet preamp for magnetic and piezo pickups.

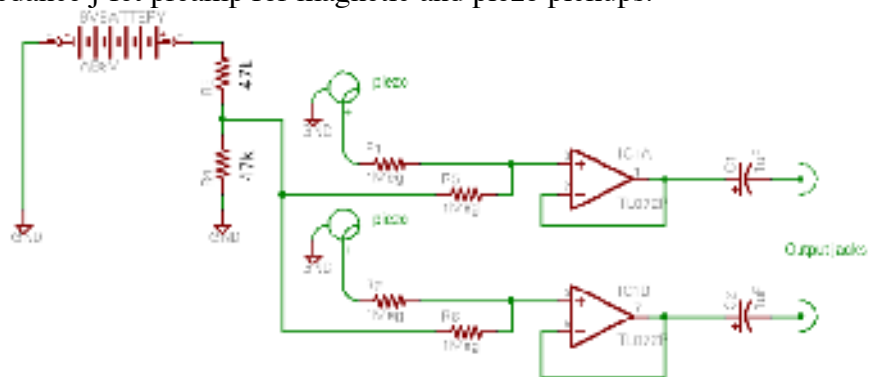

Procession-bot. Photo seeking robot.

Stupid Blue Thing. Bluetooth “plug and play” hardware interface to MAX / MSP and computer music. Developed with Clay Chaplin for NIME 2006.

Continuous capacitive reactance sensors for Chauncy Godwin.

Handmade Cellular Phones and accessories. 2.5mm wired and wireless handset designs.
“The Two-by-Phone”



UFO Theremins.



Theredwin theremin.

“Glass Aurorascope” Ground Glass Multimedia Projection Surface.

Installations, Multimedia and Visual Works

- 2006 “Ferrous Artifacts”. Interactive landscape of electromagnets and metallic resonators. Machine Project. Los Angeles.
- 2006 “Look to the Sky”. Large scale installation of 10 UFO sculptures with integrated custom theremins and 10 channel sound. Collaboration with Jay Stuckey.
- 2006 “Field Table”. Coffee table with integrated EM field sensing compasses. Wood, Aluminum, Copper, Magnets.
- 2006 Insanium II abstract speech synthesizer.
- 2005 “Blood : Brain : Barrier”. Kinetic Sound Sculpture. Copper, Electronics.
- 2005 Glass Auroscope. Tempered Glass, Wood, Sand.
- 2005-2006 Handmade Cellular Phones and Cellular Phone Accessories. Wood, Metal, Shells, Found Objects, Electronics. Notable models:
 - “The Shellular Phone”
 - “The Two by Phone”
 - “The San Quintin”
 - “The Pretty Pretty Princess”
 - “Bakelite Classic”

2005 Hammer Scan. Sheet metal sculptures of the brain.

2005 Artifact II.0. Sculptural Score. Steel, Acrylic, Electroplating, Paint & Patina.

2005 Viola Da Gamba of the Future. Wood.

2005 Insanium Abstract Speech Synthesizer.

2005 Telhydronium water instrument.

2002 "Building Night". Digital Photographs.

2002 Double Stop XY coordinate synthesizer.

2001 "Conscious Mind". Digital Video and Super 8 short film.

2001 Theredwin. Plexiglas, Metal, Theremin Electronics

1998 Electric Guitar.

1997 5 String Banjo.

1997 Pastoral Series. Oil and Acrylic on Canvas.

Performances:

2006:

Mar Vista Elementary School. Introducing robotics and electronic music to kids. Los Angeles.

Super Interesting Fun Group. Live Electronics. CalArts Main Gallery. Los Angeles.

Performance and Interview for New Wave Productions / Warner Bros. Documentary on "Forbidden Planet" Sound Track. Explained and demonstrated recreations of Louis Barron's electronic instrument methods on camera. © Warner Bros. 2006.

"20 Mule Team and the Borax Trail." 3 act dramatic & musical production featuring work by Lorin Edwin Parker. CalArts SuperShop Machine Shop.

"20 Mules / 20 Tons of Borax with Music for Tuned Canvases" Douglas Wadle, Composer. (Steam Synthesizer, Character Performance and Pyrotechnics).

BENT 2006. Third International Circuit Bending Festival. Featured Performance. Swing Space, Manhattan, New York.

M&DE at Dartington. Residency Showcase Performance. Dartington College of Arts, Totnes, Devon, U.K. (Musician and Dancer)

LA Philharmonic Presents, California Institute of the Arts, New Century Players:

In C by Terry Riley and *Minimalist Jukebox* (Contrabass).

You Too Can Play Difficult Music - Machine Project, Los Angeles.

“Farewell for the Second Time Around & Hoping to See You Again In Life” Music by David BC Leikam and Pe-eL (David Leikam and Lorin Parker). Los Angeles. (Electronics, Theremin, Robotics)

Graduation Recital of Sarah Howe. California Institute of the Arts. (Electronics, Theremin)

2005:

“Primary Colors” By Ken Christianson. CalArts (Bass)

“Remote Contrule” by Clint Haycraft. CalArts. (Actor)

“Deprivation Music for as many Strings as Possible” by Eric K.M. Clark. New Century Players – Graduate Composers Concert. CalArts. (Contrabass)

Super Interesting Fun Group (CalArts Audio-Visual Improvisation Ensemble). Roy O' Disney Hall. CalArts. (Amplified Contrabass, Glass Sculpture and Video Projections).

Outdoor Installation. Organized by Ken Christianson. (Theremin). Santa Clarita, CA.

“Bartelby” Including works by Lucier, Werder, Beuger. Experimental Music Workshop. Calarts. (Electronics. Sculptural Instruments)

Works by Christian Wolff and Michael Pisaro and Eva-Maria Houben. Experimental Music Workshop. Calarts. (Antique Valve Telegraph Machine, Function Generator, Oscillators)

David Benjamin Leikam's Mid-life Residential Crisis Concert. Calarts. (Theremin, Electronics)

“Deprivation Music II” by Eric K.M. Clark. CalArts. (Contrabass)

O.K. Composer by Phillip Stearns. Valencia, CA. (Wooden objects and hand tools)

2004:

Works by Eric K.M. Clark. Roy O' Disney Concert Hall, Calarts.(Contrabass).

CalArts Improvisation Ensemble. With Vinny Golia. CalArts. (Contrabass)

“Drift-Music” with Lewis Keller and John Summers. Improvisations. (Radios and Magnets).

2003:

“Un Mil Globos per la Pau (1000 balloons for peace)” Plaza Catalunya, Barcelona, Spain.

Two Malevolent Electrons. Monthly performances with Phillip Stearns. Denver, CO. (Theremin, Electronics)

2002:

Eurocollision. (Electric Bass)

“FlamencOrbit” by Gregory Walker. Lasers, lighting and technical director. Phipps Planetarium. Boulder, CO.

Barry Manilowe. 2002 summer tour. (backup vocalist)

After Eight Jazz Quartet. Denver, CO. (Bass)

Gann. (Bass)

2001:

University of Colorado Ensemble Performances. (Bass, Electric Bass). Denver, CO.

Auraria Cultural Festival. Auraria, CO. (Bass)

Western Swing Ensemble. Auraria, CO (Electric Bass)

Academic and Educational Activities

- 2006 Assistant Chief Steward. Dartington College of the Arts Summer School.
- 2006 Instructor “How to Make Your Robot Sing from the Heart” -- Lecture and workshop sponsored by BENT 2006, The Tank and Harvestworks. Manhattan, New York City.
- 2006 “How to Make Your Robot Sing from the Heart” -- <http://music.calarts.edu/~lorin/robotsing.html> - Online Lecture and tutorials sponsored by BENT 2006, The Tank and Harvestworks. Manhattan, New York City.
- 2006 Teaching Assistant, Electronic Music Studios. California Institute of the Arts.
- 2006 Instructor, “Creative Electronics Workshop” - Intensive interdisciplinary arts class. California Institute of the Arts. Online component at <http://music.calarts.edu/~lorinp/>
- 2006 Lecturer / Performer, “You Too Can Play Difficult Music”, Machine Project.
- 2006 M&DE, Music and Dance Exchange Resident Artist. Dartington College of the Arts, Devon, England.
- 2005 Instructor, Walk On Water. Santa Clarita California.

- 2004-2005 Coordinator, “Electro-Telharmonium Workshops” ongoing technology and design workshops. California Institute of the Arts.
- 2004-2006 Teaching Assistant, Digital Recording Studio. California Institute of the Arts.
- 2000-2005 American Red Cross, Certified Safety Instructor and Instructor Trainer. Professional Rescuer.
- 1998-2005 Private Instructor. Electric Bass, Contrabass, Composition, Interactive Design.
- 2001 Instructor / Mentor, YO! Youth Outreach Program. Denver City and County.
- 2001 Instructor, Arts Street, Mayor's Office of Theaters and Arts, Denver, CO
- 2000-2001 Teaching Assistant, Recording Studios at the University of Colorado at Denver.
- 2000 – 2004 Instructor Denver Parks and Recreation, Community Programs.
- 2001-2003 Instructor, Denver Public Schools, Community Schools Program.

Professional Activities

- Ongoing* Chief Editor: Sound Art. Cannon Canon Journal of Arts.
- Ongoing* Designer: Parker synthesizers and machines. Custom and kit based designs of electronic and mechanical instruments. Custom repair and modification of musical instruments (electronic and acoustic).
- 2006 Curator – “20 Mule Team & the Borax Trail” - Interdisciplinary performance and gallery embodying pioneering ideals of the Mojave desert region embodied by modern works of current Los Angeles residents. Featuring graphic artists, painters, composers, musical performers, puppet theater, video and performance art with a theatrical arc.
- 2005-2006 Engineer / Industrial Designer: Computer Musical Interface Project for Chauncy Godwin LLC.
- 2005-2006 Custom Interactive Wireless Sensor Design for OTIS College of Design / Mario's Furniture.
- 2005-2006 Design of custom Bluetooth wireless hardware interfaces to MAX/MSP and other music software. Developed with Clay Chaplin for NIME 2006.
- 2005-2006 Custom electronics, sound design and fabrication for artist Jay Stuckey.
- 2000-2006 Consultation, maintenance, calibration and repair of synthesizers and Professional Audio Equipment. Experience with Ampex, Studer, Moog, Linn, Arp, Serge, Digidesign, etc.

- 2005-2006 Member of Pe-eL performance duo with David B. Leikam.
- 2005 Juror, Festival co-organizer – Center for Experiments in Art, Information and Technology (CEAIT). REDCAT, L.A.
- 2003-2004 Metropolitan State Orchestra. Double bass section member. Denver, CO.

Community Service

- 2004-2006 Electro Teleharmonium Society, founder and coordinator of student led workshops and collaboratives integrating arts and technology. CalArts.
- 2000-2005 American Red Cross. Certified Safety, Water Safety and First Aid Instructor. Certified Professional Rescuer.
- 2004 Volunteer Recording Engineer – Sounding Out Concert Series. Valencia, CA.
- 2001 Urban Citizen Projects. Community Support and Activism
- 2001 Instructor / Mentor, YO! Youth Outreach Program. Denver City and County.
- 2001 Instructor, Arts Street Program, Mayor's Office of Theaters and Culture, Denver, CO
- 1995-1997 Volunteer Instructor, Denver Museum of Nature and Science

Recordings:

- 2004-2006 Internet publication of recorded works.
- 2005 BENT 2005 DVD. Absurdity-biz.
- 2005 Pe-eL, live at Il Corral. I-Senses / Musatlity.
- 2005 Improvisation with Andre Vida and Rich O' Donell. VidaTone Records.
- 2003 “Collected Archives” Self published.
- 2003 “Trilogy Vocalise” Self Published.
- 2001 “Impatient”. Self published.

Audio Engineering:

- 2006 Morton Subotnik and Joan LaBarbra. “Create Music” software.

- 2006 Mark Trayle and Michael Fink. CalArts.
- 2005-2006 Assistant to the director of studios. Dizzy Gillespie recording studio and electronic music studios. CalArts.
- 2005 Toshi Nakamura and Mark Trayle. Improvisational Music of Japan (Toshi Nakamura).
- 2005 “Child Real Eyes” - Anthony Braxton, Andre Vida. Released LP (VidaTone).
- 2002 “Works by Berge” Gregory T.S. Walker, Conductor. Orchestra musicians from University of Colorado and Boulder Philharmonic. Recorded for the University of Colorado.
- 2001-2002 Teaching Assistant. University of Colorado Recording Studios.
- 2001-2002 Asst. Maintenance Engineer – Core Studios, Denver CO

Writings, Articles

- Ongoing* Chief Editor: Sound Art. Cannon Canon Journal of Arts.
- 2006 “Virtuosity and the Nature of Art as energy – How a Flute Can't Reheat Your Coffee” - Paper for “Difficult Music” series. Published by Machine Project, Los Angeles.
- 2005 “Treatise for the Re-establishment and Propagation of Aesthetic Growth in Technology”
- 2004-2005 Online tutorials and methods for incorporating technology and the arts.
<http://music.calarts.edu/~lorinp/>

Research:

Creation and presentation of multidisciplinary works. Multidisciplinary art theory.

The role of the computer and “ubiquitous computing” in arts and culture

Technology and arts history 1970-1986.

19th Century technology and arts history.

Automata

Visual and aural perception and attention.

Steam engines and kinetic sculpture.

Speech synthesis

Early synthesis – the Theremin, Trautonium, Ondes Martinot, Telharmonium, Katzenclavier, Voders, Ocular Harpsichord.

Scientific instruments and the arts.

American western history.

Professional Associations

Cannon Canon Journal

ASCAP

Audio Engineering Society

Notable Collaborators

Electronic Music: Clay Chaplin, David B. Leikam, Gregory TS. Walker, Andre Vida

Choreography: E. Kim

Puppetry: Laurie O'Brien

Fine arts: Jay Stuckey

Practical Skills

Sculpture

Woodworking

Metalworking, Machining

Puppetry (marionette and hand)

Stage Acting

Digital Video

Digital Photography

Film (8mm, 16mm)

PIC Microcontroller Programming and design

Electronics design, simulation, circuit board design.

Computer music – MAX/MSP, Csound, ProTools, Digital Performer... etc.

Recording Studio Maintenance and Calibration

Programming – C, JavaScript, HTML, UNIX, OSX.

3d and Industrial Design

CAD – Electrical and Design

Fabrication, Prototyping

Oil Change on 1988 Volvo